

DETAIL A
SCALE 5 : 1

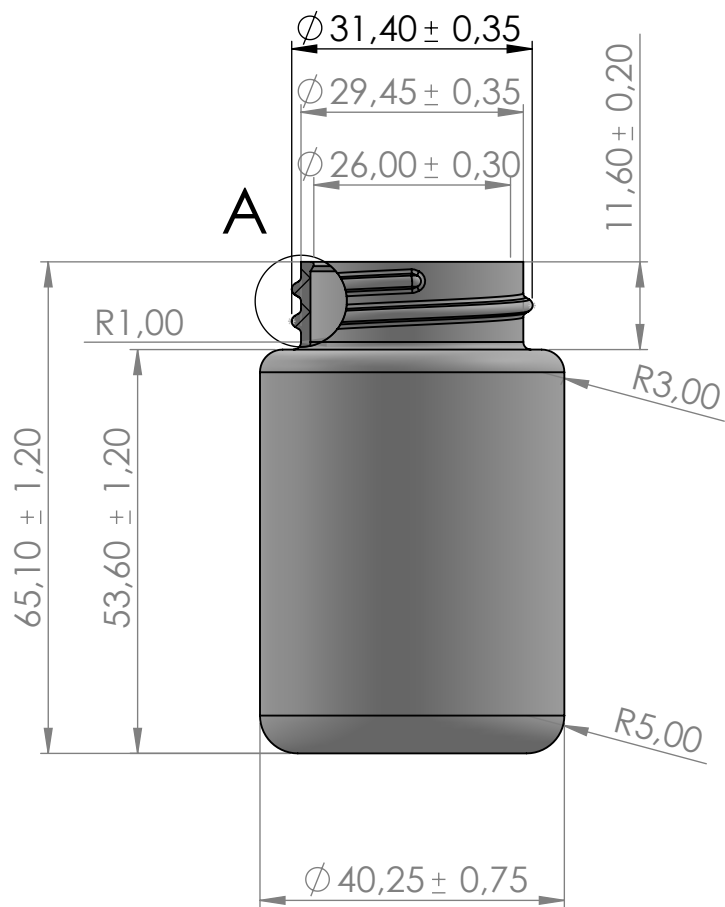

NOTES:

1. TOLERANCES UNLESS OTHERWISE STATED

- 50 ± 0,50
- 51 - 100 ± 1
- 101 - UPWARDS ± 1,5

2. WALL SECTION TO BE 1,0 NOMINAL
0,5 MINIMUM IN BLOW CORNERS

3. THREAD TO BE SINGLE START

RIGHT HAND 4,25 PITCH 1,25 FULL
TURN PLUS RUNOUT

PROPRIETARY AND CONFIDENTIAL

THE INFORMATION CONTAINED IN THIS DRAWING IS THE SOLE PROPERTY OF ILHAPLAST. ANY REPRODUCTION IN PART OR AS A WHOLE WITHOUT THE WRITTEN PERMISSION OF ILHAPLAST IS PROHIBITED.

APPROVED

REVISION

00

ILHAPLAST

REVISION	DESCRIPTION	DATE: 01-10-2015
		MOULD N.º: MIP-040&041, Neck 33/400 BSR3 33
		MATERIAL: HDPE
		NOMINAL/OVERFLOW CAPACITY: 60/64.5 ml
		WEIGHT: 8.5 g
		DRAWN BY: JD

TITLE:

FRA 91, 60 ml

A4

SCALE: 1:1

SHEET 1 OF 1