

SECTION A-A

NOTES:

1. TOLERANCES UNLESS OTHERWISE STATED
 $50 \pm 0,50$
 $51 - 100 \pm 1$
 $101 - \text{UPWARDS} \pm 1,5$

2. WALL SECTION TO BE 1,0 NOMINAL
 0,5 MINIMUM IN BLOW CORNERS

3. THREAD TO BE SINGLE START

RIGHT HAND 4,25 PITCH 1,25 FULL
 TURN PLUS RUNOUT

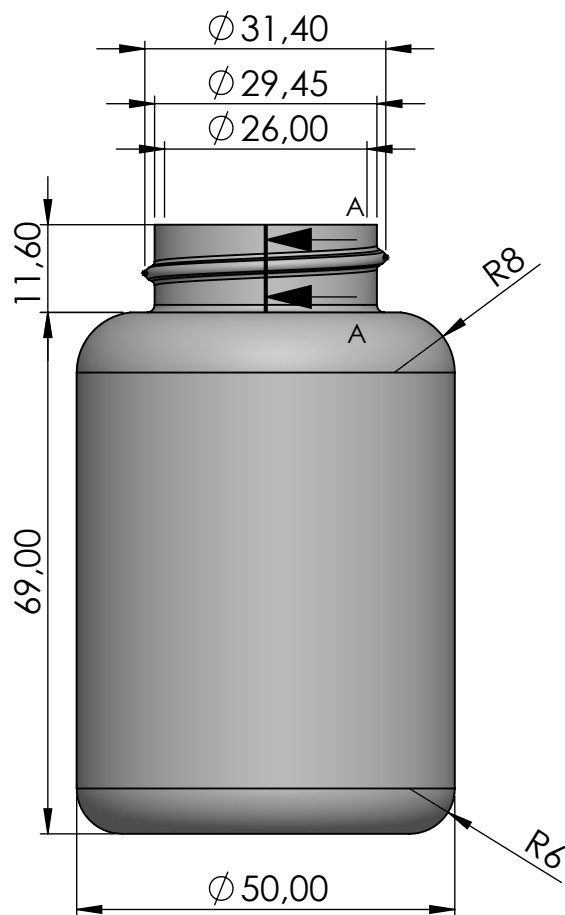

PROPRIETARY AND CONFIDENTIAL

THE INFORMATION CONTAINED IN THIS DRAWING IS THE SOLE PROPERTY OF ILHAPLAST. ANY REPRODUCTION IN PART OR AS A WHOLE WITHOUT THE WRITTEN PERMISSION OF ILHAPLAST IS PROHIBITED.

APPROVED

REVISION

00

ILHAPLAST

REVISION

DESCRIPTION

DATE: 30/09/2015

TITLE:

MOULD N.º: MIP-033, Neck 33/400 BSR3 33

MATERIAL: HDPE

NOMINAL/OVERFLOW CAPACITY: 100/120 ml

WEIGHT: 19g

Fra 19- A, 100 ml

A4

DRAWN BY: JD

SCALE: 1:1

SHEET 1 OF 1